

Cweco

Commercial Washroom Equipment Company Incorporated

P.O. Box 2456, Gardena, CA 90247-0456 310-538-9440

1-800-292-9326 Outside CA FAX: 310-715-9188

FAX 1-800-232-9326

V422

UTILITY SHELF

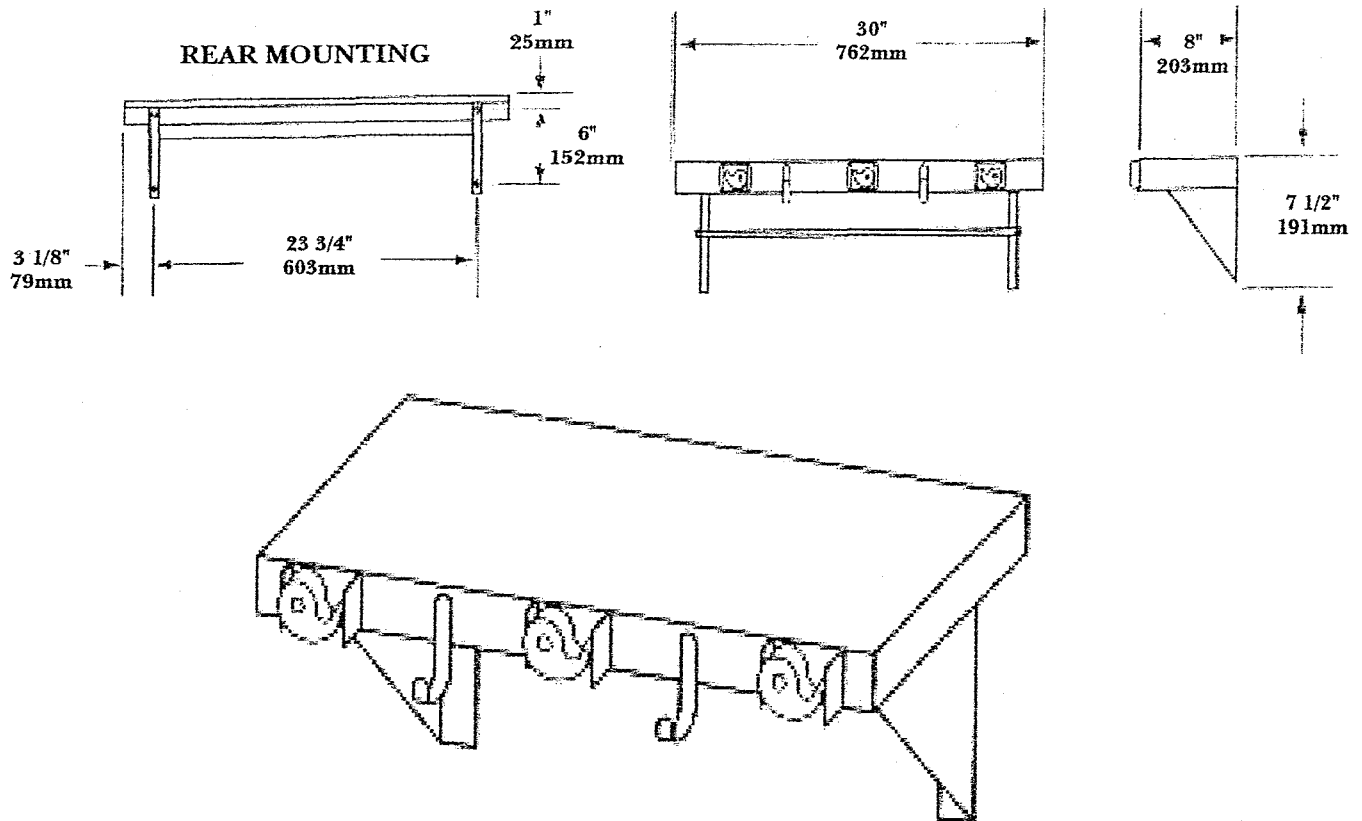

SPECIFICATIONS:

UNIT FABRICATED OUT OF 18-8 TYPE 304 STAINLESS STEEL WITH EXPOSED SURFACES HAVING A #4 SATIN FINISH. ALL WELDED CONSTRUCTION. SHELF BRACKETS ARE FABRICATED OUT OF 16 GAUGE (1.6mm) TYPE 304 STAINLESS STEEL AND WELDED TO SHELF. UNIT PROVIDED WITH 16 GAUGE (1.6mm) TYPE 304 STAINLESS STEEL HOOKS, AND RUBBER MOP HOLDERS, AND STAINLESS STEEL TOWEL DRYING ROD.

OVERALL DIMENSIONS:

30"(762mm)W x 7 1/2"(191mm)H x 8"(203mm)D